



MT Produktion GmbH
Galinastraße 18
A-6710 Nenzing

www.m-track.eu

Data sheet

MTrack GBL460

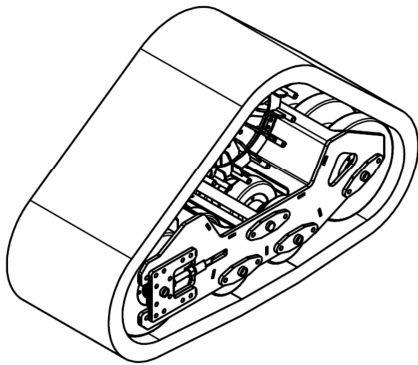

MTrack GBL 460

Track system GBL460 for medium-sized tractors between 100 hp and 150 hp

1 Weight

The weights of the Track system GBL460 are as follows:

Track system 2110 kg
 Vehicle attachments 410 kg
 Total 2520kg

Maximum speed allowed on the road: 25 km/h
 Maximum permitted speed in the field: 10 km/h

Maximum permissible total axle load on the front axle: 3500 kg
 Maximum permissible total axle load on the rear axle: 6500 kg

2 Dimension

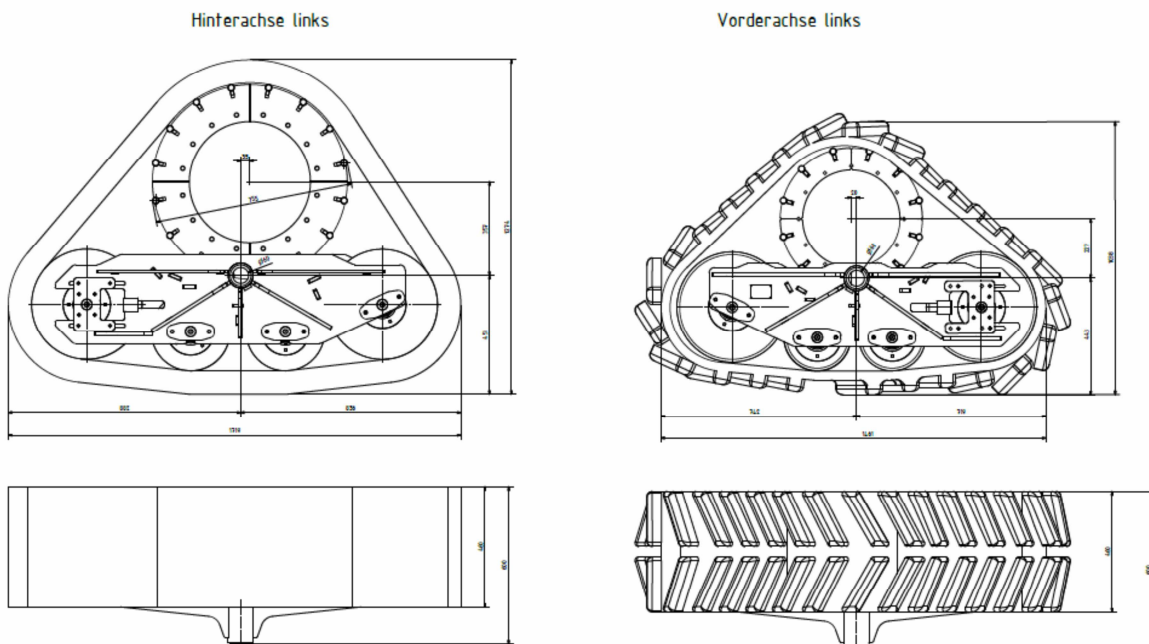

3 Speed

Reduction of the vehicle speed using the Massey Ferguson 5711M as an example

MF 5711M with municipal tires RA 540/65 R38 with D=1665mm

-> $v_{(max)} = 45 \text{ km/h}$ with wheels

MF 56711M with Track system GBL 460 RA with D=755mm

-> $v_{(max)} = 20.5 \text{ km/h}$ with Track system GBL460

